

**OIL MIST LUBRICATION FOR
THE PETROCHEMICAL INDUSTRY**

**by
Charles A. Towne
Consultant
Houston, Texas**



from
Proceedings of 11th International Pump Users Symposium.
Copyright 1994. All rights reserved. Reprinted with permission of
the Turbomachinery Laboratory, Department of Mechanical Engineering,
Texas A&M University, College Station, Texas 77840-3123.

OIL MIST LUBRICATION FOR THE PETROCHEMICAL INDUSTRY

by
Charles A. Towne
Consultant
Houston, Texas



Charles A. (Charlie) Towne was a Staff Engineer with Manufacturing Technical Support Department of Shell Oil Company with 35 years of service. Mr. Towne retired from Shell in 1993 and is currently doing consulting. He received a B.S. degree in Mechanical Engineering from Bradley University before joining Shell at the Fuels and Lubes Research Laboratory. He was assigned to the Head Office Research and Development, Tech Liaison with Advertising, Deer Park Manufacturing Complex Rotating Machinery Group, and Head Office Lubrication/Seal Specialist.

In his last assignment, he was Lubrication Specialist for Manufacturing. He recommended products, provided troubleshooting for problems, provided training, established lubrication schedules, etc. He also served as focal point for mechanical seals issues, including emissions requirements.

He is a member of STLE (formerly ASLE) and STLE Seals Technical Committee Work Group 3 (Fugitive Emissions), and he is on the Technical Advisory Group for the Texas A&M Oil Mist Research Program.

ABSTRACT

Oil Mist lubrication has been shown to be a very effective method for reducing maintenance costs by minimizing lubrication related bearing failures. What oil mist is, how it works, and typical results from its application is explained. A properly designed and operated oil mist system is normally not detrimental to the environment.

INTRODUCTION

Performance goals throughout the petrochemical industry for the last few years have been increased reliability and efficiency and extended run times, while reducing maintenance and operating costs. This presents many opportunities for innovation and application of new technology. Yet, one very significant means for achieving these objectives has been overlooked or avoided for many years. That means is oil mist lubrication.

Oil mist lubrication has been available since the 1930s when it was introduced by a Swedish bearing manufacturer to lubricate high speed spindle bearings in machine tools. It has only been in the last 10 to 15 years that oil mist has played an increasing role in the petrochemical industry. Objections ranged from "it will never work" to "its too messy" to "its too expensive." These attitudes are still held today. But the advantages of oil mist for reducing energy consumption, reducing costs, and increasing run times should be seriously considered.

The following subjects are discussed:

- Why use oil mist?
- How does it work? System design and operation..
- What's next? (the future)

Potential problems with oil mist will be discussed where appropriate.

WHY USE OIL MIST?

The first question to be asked is "Why use oil mist instead of what I'm using now?" The biggest reason is that oil mist can significantly reduce the number of lubrication related bearing failures in petrochemical plants. Many technical papers on the subject (1, 2, 3, 4, 5, 6, 7, 8, 9) have demonstrated such performance. Generally, reductions in bearing failures range from 50 percent to 90 percent in a variety of applications. In one large petrochemical plant, bearing failures in two similar units with a population of about 200 pumps each were compared. One had mist; the other had conventional lubrication. The unit on oil mist had about 85 percent fewer bearing failures. Electric motors can also benefit. Two West Coast plants had similar expansion projects at the same time. One plant used oil mist on the motors; the other did not. During 3-1/2 years operation, motor bearing failure rate was about 90 percent lower at the plant using oil mist.

Most studies of oil mist lubrication have been empirical evaluations conducted in the field. Very often, they have been trial and error attempts which have produced excellent results. Recently, researchers at Texas A&M have conducted carefully controlled scientific studies [10] on the mechanism and benefits of oil mist lubrication. Their tests showed a reduction in thrust bearing temperature in the neighborhood of 18°F compared to conventional lubrication. They also showed a reduction in friction of about 25 percent. Both of these reduction clearly point to reduced operating cost and increased bearing life.

Other advantages of oil mist lubrication besides reducing friction and increasing bearing life are:

- Better availability of standby equipment.
- Reduced operating manpower for lubrication.
- Reduced lubricant consumption compared to conventional lubrication.
- Lubricant misapplication eliminated.
- Reduced seal failures (pumps).

While oil mist has many positive attributes, there are also some negatives. These are often cited as being messy, an environmental concern and a potential safety problem. Negative side effects and methods to deal with them will be discussed at the appropriate places herein. But, a properly designed, operated and maintained oil mist system can overcome any of the side effects.

THE OIL MIST SYSTEM – BASICS AND DESIGNS

An oil mist system is a central lubrication system that supplies oil from a central reservoir to a number of remote points. It satisfies the "four R's" of lubrication; to get the

- Right amount, to the
- Right place, at the
- Right time, using the

Right kind of oil.

An oil mist system consists of generating console where the mist is made, header system which transports the mist to the lubrication point, reclassifiers where mist particle size is increased, vents, and drains. A typical once-through, single line system is shown in Figure 1. A more advanced, complicated closed loop system is shown in Figure 2. In the single line system, oil mist is used once, whereas the closed loop system collects the oil and reuses it. Both have advantages. Both have disadvantages. Primary advantages of the single line system are simplicity and cost. Disadvantages are oil disposal and stray mist. Advantages for the closed loop system are elimination of oil disposal, reduced stray mist and reduced oil costs.

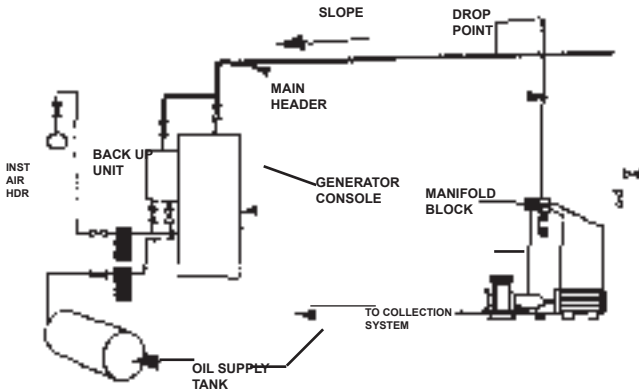

Figure 1. Single Line System

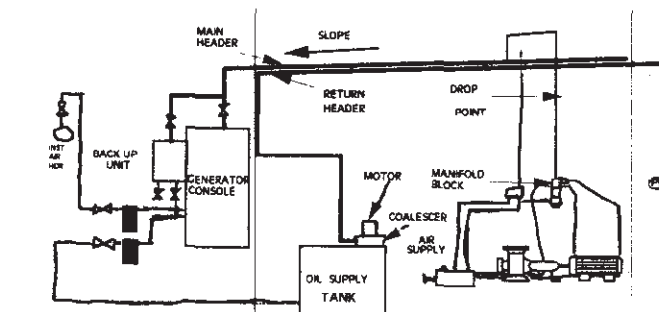

Figure 2. Closed Loop System

Disadvantages are complexity, increased equipment and increased costs. Distinctions between the systems will be discussed as they arise.

Oil and Air Supply Systems

Two important features of an oil mist system are the oil and air supply systems to the console. Air is normally provided from the instrument air header. It was selected because it is the most reliable and driest source of air in a refinery or chemical plant. If the instrument air system fails, the entire plant gets shut down. Oil supply ranges from manual fill, to drums, skid tanks or large supply tanks (10000 gal). Each user must make an independent decision on what supply system to use. But, in general, manual fill on large systems should be avoided. Oil supplied to an oil mist system must be kept as dry as possible. Water can lead to suction screen and generator head plugging. Both the air and oil systems should be provided with nonlinting filters.

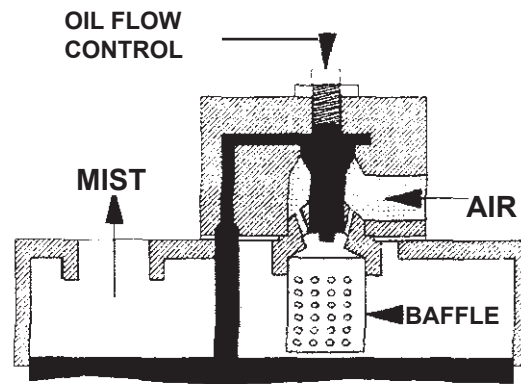

Figure 3. Venturi Mist Generator Head

Generating the Mist

An oil mist generator is basically a venturi where high velocity air creates low pressure as it flows through a restriction. The reduced pressure caused oil to be lifted from a reservoir and atomized as it is impacted by the high velocity air stream. Different vendors use different generator head designs for making mist. A simple venturi arrangement is shown in Figure 3 while a vortex-type mist generator head is shown in Figure 4. Operation of a mist generator head is exactly the same principle as a carburetor on an automobile. The oil flow control valve is equivalent to an idle mixture adjusting screw.

The most important factor in selecting a mist generator head is not the type but size. A mist generator head must be sized to match its application. While it is often desirable to size equipment for future expansion, this is not necessarily a good thing to do with the mist generator heads. Mist generator heads do not operate well at the low end of their operation range. Mist production is erratic since velocity though the venturi is inadequate to lift the oil from the reservoir.

If an oversized generator head is specified, unnecessarily large reclassifiers must be used to get the generator head operating point farther out on its curve. Otherwise, poor mist quality will result. The larger reclassifiers will result in over oiling, housekeeping problems, excessive stray mist and wasted energy. Select a generator head size that meets current system requirements at about the midpoint of its pressure vs air flow curve. This will handle existing needs and probably most future expansions.

Header System

Once mist is produced, it must be transported to the lubrication points. This is done in the header system. In large scale oil

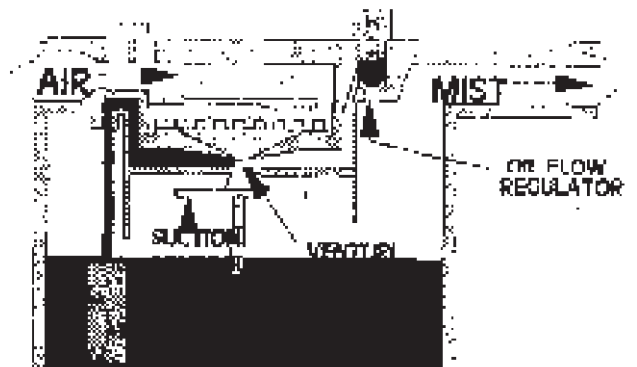

Figure 4. Vortex Mist Generator Head

mist systems, the main header is usually 2.0 in galvanized pipe. As shown in Figure 1, the main header should slope continuously back toward the console in all cases possible. This permits any oil that coalesces in the pipe to be returned toward the console in all cases possible. This permits any oil that coalesces in the pipe to be returned to the generator reservoir. It also does away with excessive and unnecessary drain legs. The only two valves used in an oil mist system are the ones used to switch between the main and backup units. No other valves should be used in a header system.

Often, branch headers are required to reach equipment located off the main header run. If a run of more than 35 to 40 ft is required for a branch header, 2.0 in galvanized should be used. Shorter runs can use 3/4 in pipe. All branch headers should come off the top of the main header and all branch headers should be sloped continuously downward toward the main header. Piping should be free from leaks and assembled with a light coat of PTFE-containing paste a couple threads back from the end of the pipe. Never use PTFE tape in an oil mist system between the generator head and bearing housing.

Drain Legs

In some instances, it is necessary to use a drain leg at the end or middle of a system. They are usually required where a change in elevation or a loss of clearance in an overhead pipe rack occurs. *Drain legs should be avoided in all cases possible.* If they must be used, two workable designs are given in Figures 5 and 6.

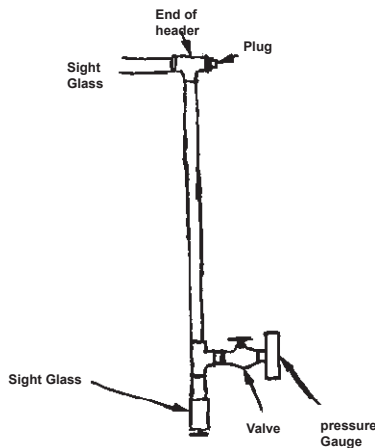

Figure 5. Drain Leg-Single Line

A simple drain leg system is shown in Figure 5, with a clear sight glass that permits draining as required. The more sophisticated drain leg in Figure 6 includes a drain leg manifold assembly, reservoir, float switch, air solenoid, air pump and two return lines (one for stray mist and one for liquids).

Drop Points

A “drop point” is used at each piece of equipment to be misted. The drop point comes off the top of the main or branch header and terminates above the equipment in a “manifold block” or “mist manifold.” Drop points are usually 3/4 inch pipe and come off the top of the header to minimize liquid oil accumulation in the manifold block. Horizontal runs of drop points should be sloped downward toward the main header. They should terminate high enough above the equipment to be out of the way when machinery repairs are required.

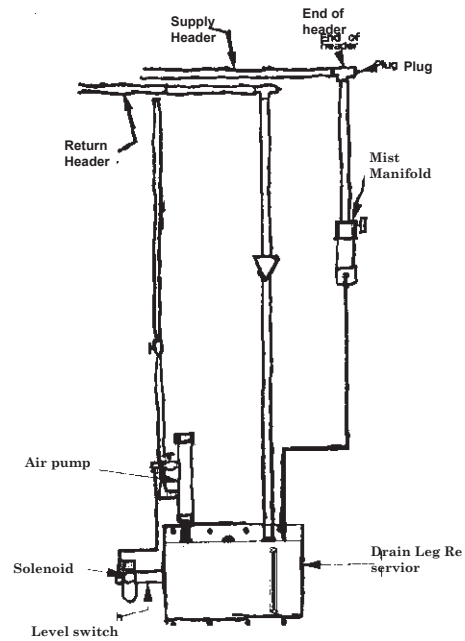

Figure 6. Drain Leg-Closed loop

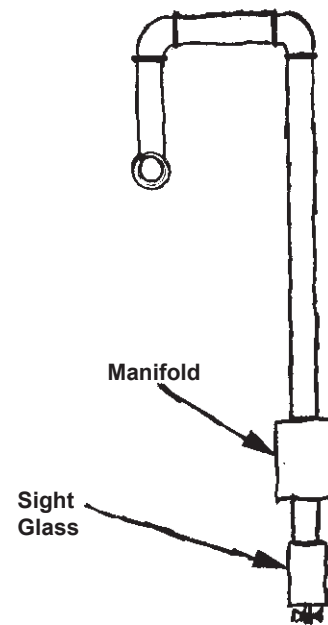

Figure 7. Drop Point-Early Style

Manifold Block

Manifold blocks, or mist manifolds, are the connection between the header system and the piece of equipment being lubricated. The only functions of manifold blocks are to provide a place to locate the reclassifiers and to collect any liquid mist that should coalesce in the drop point. In a properly designed and operated system, the amount of oil to be collected here is minimal. An early design that uses manual draining is shown in Figure 7, while a newer design connecting the mist manifold to an oil collection container and a return manifold to an oil collection container and a return manifold assembly is shown in Figure 8.

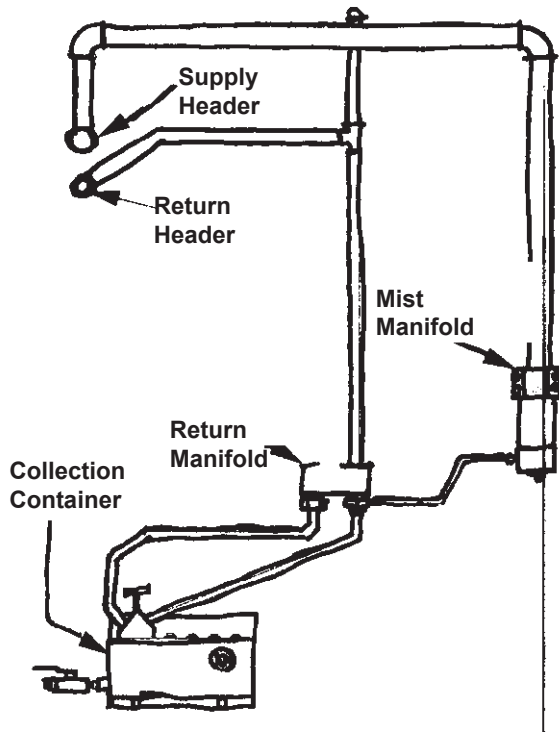

Figure 8. Drop Point-Closed Loop

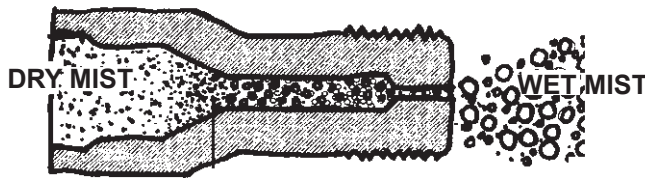

Figure 9. Mist Reclassifier

Reclassifiers

Reclassifiers or mist fittings are devices that increase the mist particle size by accelerating the mist through a small orifice. The increased velocity and turbulence causes impaction of small particles and agglomeration into larger particles. Reclassifiers are most often located in the manifold block, but in some cases, can be located on the equipment bearing housing. Different types of mist fittings are available depending upon the degree of "reclassification" desired ranging from mist to spray to condensing. Each type has its own delivery rate based upon orifice size and main header pressure. A typical mist reclassifier is shown in cross section in Figure 9.

In general, the smallest reclassifier that will adequately lubricate the bearings should be used. Oil mist vendors have equations that show how to calculate reclassifier size. The equations include a "service factor" term. Normally, the moderate duty service factor has been completely satisfactory in all but the very most severe cases (high temperatures caused by sustained, excessive thrust loads). Larger reclassifiers cause excessive stray mist and potential housekeeping problems.

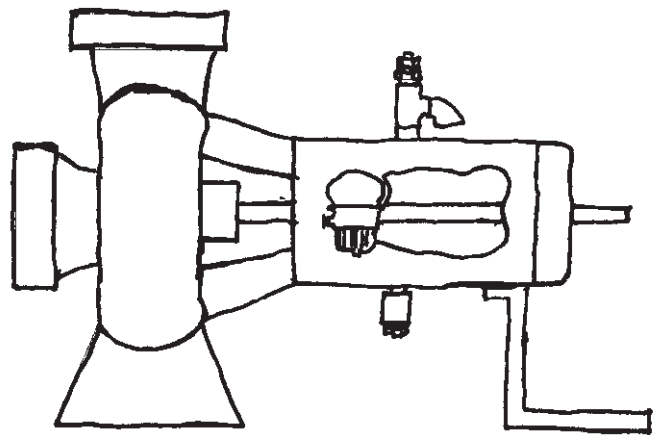

Figure 10. Purge Mist

Equipment Connections

Purge Mist

Bearing housings can be connected to oil mist in two ways. The first is called "wet sump" or "purge mist" while the second is "dry sump" or "pure mist." When oil mist is connected as wet sump, the mist is used only to purge the bearing housing. Oil is retained in the bearing housing at its normal level. Lubrication is provided in the normal manner. The main advantage of using purge mist is to provide a slight positive pressure in the bearing housing to exclude atmospheric contaminants. This is particularly important in stand-by equipment where intrusion of contaminants can significantly shorten bearing life. A typical "wet sump" connection is shown in Figure 10.

Some type of venting or pressure balance is mandatory when purge mist is used. Otherwise, the oil will be pressurized out of the bearing housing. If a pressure balance device is used, the conventional constant level oiling device is not required. When a vent system as shown in Figure 10 is used, reclassifier size should be minimized

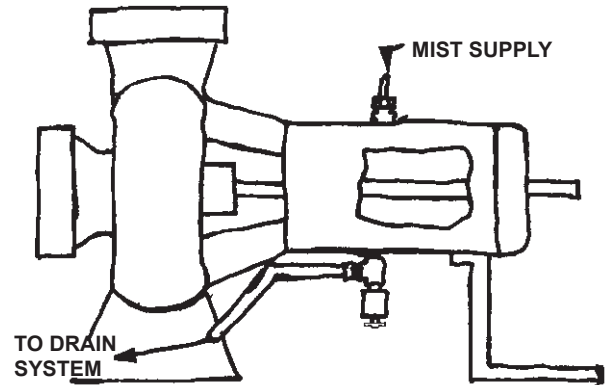

Figure 11. Pure Mist-ANSI Type

to provide just enough flow for a slight positive pressure. Venting systems are discussed below in more detail.

Purge mist is typically used for sleeve bearing applications since it is extremely difficult to provide enough liquid oil with oil mist to do the lubrication job effectively. If a piece of equipment using rolling element bearings is known to be operating at sustained high thrust loads, purge mist should be used. But, for the vast majority of rolling element bearing applications, pure mist is the method of choice.

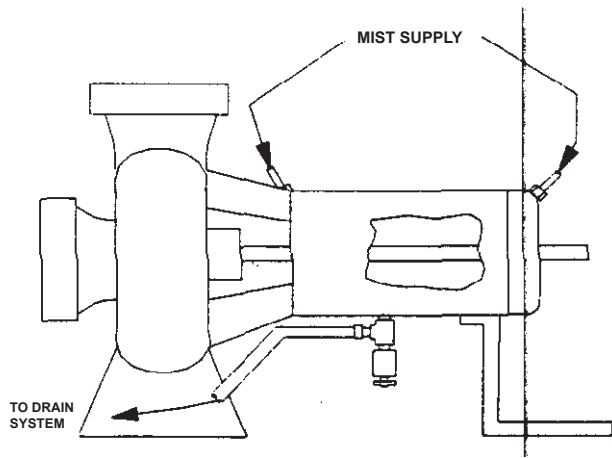

Figure 12. Pure Mist-API Type

Pure Mist

In a pure mist application, all the oil is drained from the bearing housing and all lubrication is provided by the oil mist only. The constant level oiling device is removed and the liquid oil that coalesces in the bearing housing is collected in a manner consistent with the requirements of the refinery or chemical plant. For ANSI pumps, a scheme such as shown in Figure 11 is normally used, while API 610, 7th edition recommendations are shown in Figure 12.

Drain Systems

Drain systems can be as simple as the one shown in Figure 11 or as complicated as shown in Figure 13. The individual refinery or

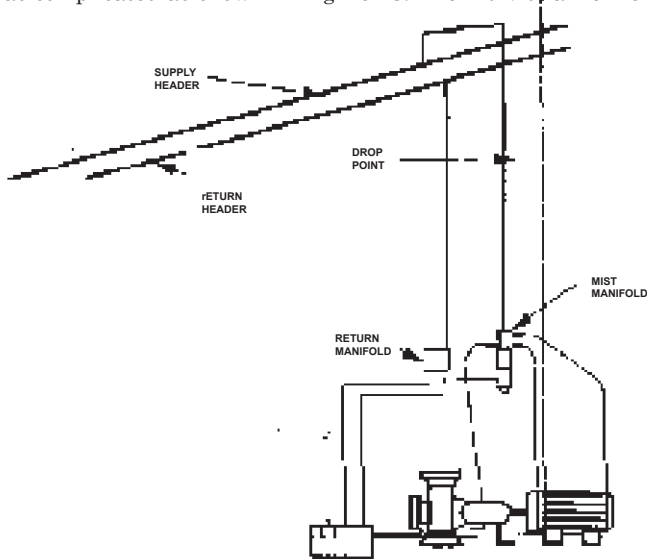

Figure 13. Closed Loop Drain System

chemical plant's requirements will be the determining factor. As will be discussed later, a number of tests have demonstrated that oil mist liberated to the atmosphere is far below any environmental requirements. However, the difficult part is often dealing with the liquid oil. Since the amount of oil contributed by an oil mist system is quite low compared to other sources, connecting to an oily water sewer is acceptable in many plants. But, in some chemical plants, there is no oily water sewer, so the liquid oil must be collected in larger containers and subsequently drained.

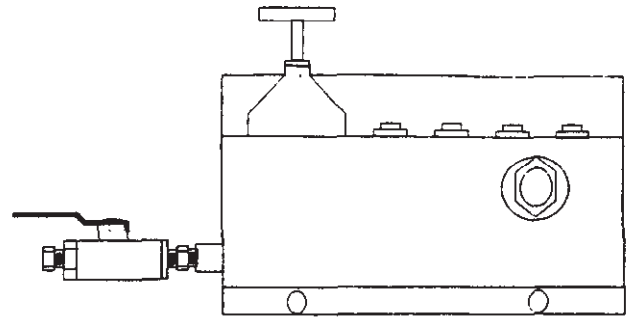

Figure 14. Drain Pot-Multi Connections

Extensive experience with oil mist for more than a decade and a half has demonstrated that extra venting for pure mist bearing housings is not required. What is necessary is that a continuous supply of fresh oil mist reach the bearing housing and that the liquid oil be carried away [9]. A drain system solves this problem.

One approach is to merely use a large, see-through container that can be dumped when it is full. Another approach is to use a closed container with a sight glass that can, again, be manually drained. The most sophisticated approach uses a closed container with a sight glass and a hand pump. When the container fills, it is manually pumped overhead to the oil return header (Figure 14).

Small sight glasses as shown in Figure 11 are often used for both pure and purge mist applications. These devices are quite valuable for visually observing the condition of oil in the bottom of the bearing housing or oil being drained. Water leaking into bearing housing will be found in the sight glasses. On pure mist applications, the sight glass also provides a means to observe oil mist flow at the pump.

But, there are some potential problems. An operator unfamiliar with purge oil mist could mistakenly drain all the oil from a bearing housing by opening the valve under the sight glass. Another difficulty can be that if an operator should drain a sight glass on a pure mist application, the valve could be left open. This will create a housekeeping problem under the pump. And, if the pump is an ANSI model, there is often not a drain lip, so the oil will leak to the pad causing a potential environmental or slip problem. Both problems can be avoided by proper training. An alternative would be to omit the sight glasses while recognizing that their advantages will be lost.

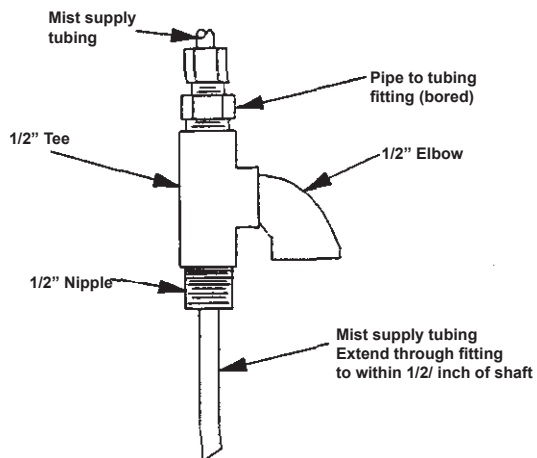

Figure 15. Purge Mist Vent

Vents

Pure mist applications do not require drilling additional holes to provide venting. The goal is to provide oil mist flow through the bearing housing. Adequate drain systems on API and ANSI pumps provide a sufficient path for flow and venting. Hence, additional venting is not required.

Purge mist is different matter. Without adequate venting on a purge mist bearing housing, the oil can be pressurized out of the housing. Two approaches are used to provide adequate control for purge mist applications. A system such as shown in Figure 15 provides an inexpensive means of venting the bearing housing without requiring any modifications to the existing hardware.

A closed system is shown in Figure 16 where the pressure above and below the oil level is balanced. This system is more expensive and more complicated than the one in Figure 15, but has the advantage that it can minimize stray mist to the atmosphere. In an API pump, a pressure balancing device such as this will not have much impact on stray mist through the labyrinth seals. But, on tight ANSI pump bearing housing with purge mist, these devices should work well.

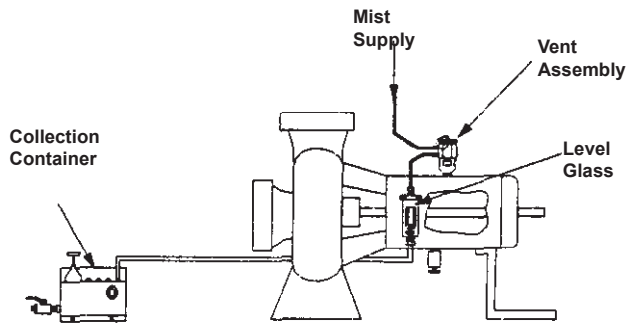

Figure 16. Purge Mist-Closed Loop

A closed system is shown in Figure 16 where the pressure above and below the oil level is balanced. This system is more expensive and more complicated than the one in Figure 15, but has the advantage that it can minimize stray mist to the atmosphere. In an API pump, a pressure balancing device such as this will not have much impact on stray mist through the labyrinth seals. But, on tight ANSI pump bearing housing with purge mist, these devices should work well.

The main purpose of purge mist applications is to provide a small, positive pressure in the bearing housing to prevent intrusion of atmospheric contaminants. The absolute maximum pressure that could be attained in a bearing housing is 20 in water (maximum header pressure). This will keep atmospheric contaminants out very well. But, a leaking carbon ring seal on a steam turbine can allow steam to blow along the shaft towards the bearing housing at a much higher pressure. Hence, a pressure balanced system may not be effective in this case. A mechanical deflector or air barrier may be needed. If only atmospheric contaminants are to be excluded, 0.5 in water will work just as well as 20 in water. The oil mist user must decide what is to be accomplished.

What Equipment Gets Oil Mist?

This question is frequently asked. Oil mist has been successfully applied to equipment such as pumps, motors, gear boxes, steam turbines, and other miscellaneous rotating equipment. It has also been used as a preservation technique for mothballed equipment or

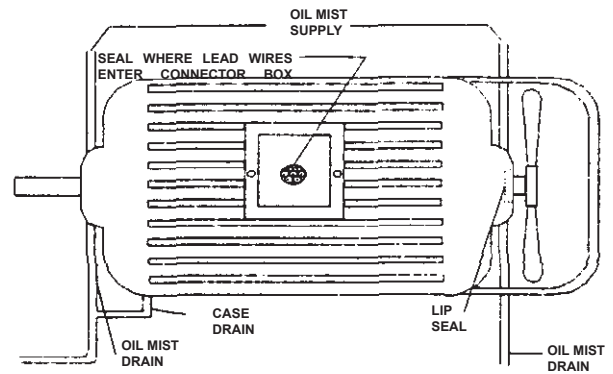

Figure 17. Typical Electric Motor Connection

new equipment awaiting installation. Special considerations must be given each application. In general (but not always), pumps and electric motors with rolling element bearings will use pure (dry sump) oil mist. Gear boxes and steam turbines normally use purge mist. Further, electric motors are a special circumstance and must be evaluated on a case-by-case basis. TEFC motors can normally use pure mist, but oil mist is not recommended for open or explosion-proof motors. Major criteria are winding and lead wire insulation systems. They must be compatible with oil. One successful method for connecting oil mist to TEFC motors is shown in Figure 17.

Controls and Alarms

There is a wide diversity in control and alarm systems available. One system uses solid state sensors and controllers with digital output while another uses analog signals and output. Reliability, ease of operation, and cost are often key factors when choosing an oil mist system. A user must decide which elements are most important in the selection process. The main questions to be answered are: "Does this unit make consistent quality mist?" and "Will this system tell me reliably if something should go wrong?" If both questions can be answered "yes," the system is acceptable.

Regardless of the alarms and controls employed, the heart of the system is still the generator head. One point to keep in mind is "If you have air and you have oil, you should be making mist." If you are not, you have a plugging problem in the generator. Either the flow control valve or suction screen is plugged on the venturi type head or the suction screen is plugged on the vortex type. Another possibility is oil viscosity is too high caused by either the wrong oil installed or a heater failure in cold weather.

Controls are provided to maintain oil and air temperatures and oil level at the correct settings. The oil heater helps keep the oil at a constant temperature, hence, a constant viscosity for proper atomization. Higher viscosity oils require more heat to atomize well. Excessive temperatures (over 160°F) can lead to accelerated oxidation. Typically, oil temperature is maintained at 110°F. Air heaters are used to assist atomization and to help transport mist through the header. Typical air temperature is 140°F.

Oil level controls help provide consistent mist quality. As oil level drops, mist quality changes. And, as discussed earlier, oil viscosity can have a significant effect on mist quality. So, if the oil level were permitted to vary over a wide range, mist quality would deteriorate as level fell, then become even worse when a fresh charge of cold oil is admitted. For these reasons, oil level is controlled over a very narrow range (1/2 to 3/4 in) to help provide consistent mist quality.

Other controls include an air pressure regulator and an air/oil density adjusting screw. The air pressure regulator adjusts pressure supplied to the generator, so that the mist header pressure is held at a constant level. Typical mist header pressure is 20 in water. In some cases, if the header pressure changes, an operator will adjust the pressure regulator to compensate for the changes. *This should not be done!* If header pressure has changed from the preset values, something in the system has changed. Adjusting the regulator masks the problem and can lead to more serious problems. Should header pressure change, either higher or lower, the operator should locate the source to the problem in the system rather than merely adjusting the pressure regulator.

The oil/air mixture screw can be adjusted over a fairly wide range to change oil mist density. A good general practice is to use as lean an oil/air mixture as practicable to assure proper lubrication. Experience has shown that an oil/air ratio of 0.5 cu in (oil)/cfm (air)/hour works well. A lean oil/air mixture reduces oil and air consumption, reduces stray mist and reduces liquid oil in the drain system. There are no set rules. Each user must determine their own limits for oil/air ratio on keeping with their requirements for equipment life and environmental compatibility.

Alarms are typically provided for air temperature, oil temperature, oil level, and mist header pressure. Other points sometimes included are supply oil pressure, supply air pressure, and regulated air pressure. Each parameter has a design operating set point plus low and high alarm set points. Alarms can be either local, in a remote control room, or both. In any event, when an operator gets an alarm, the system must be investigated immediately to detect the problem. Remember, all the pumps in an entire operating unit can be at stake.

A gray area for alarms and controls is oil mist density. A number of mist monitors have been marketed over the years, but none have performed accurately and reliably for extended periods. The best assurance that mist density is adequate is for routine checks for mist at the last pump in a system. Checks should be made *at least* twice a shift. If problems are encountered, the backup generator can be started while the main generator is repaired.

Oils for the mist System

What oil should be used in an oil mist system? Should we use mineral oils or synthetics? There are as many answers as there are users of oil mist systems. The important criteria are that the oil must have sufficient viscosity to lubricate equipment on the system, it must mist well, it must not produce excessive stray mist and it must have a pour point high enough to prevent cold weather problems. Experience, in the absence of scientific testing, has shown that an oil with a pour point 20°F above the lowest anticipated temperature will perform well in cold weather. In Southern climates, high-quality, R & O turbine oil will normally do well. In Northern climates, a synthetic might be needed.

A gray area for alarms and controls is oil mist density. A number of mist monitors have been marketed over the years, but none have performed accurately and reliably for extended periods. The best assurance that mist density is adequate is for routine checks for mist at the last pump in a system. Checks should be made *at least* twice a shift. If problems are encountered, the backup generator can get started while the main generator is repaired.

Oils for the mist System

What oil should be used in an oil mist system? Should we use mineral oils or synthetics? There are as many answers as there are users of oil mist systems. The important criteria are that the oil must have sufficient viscosity to lubricate equipment on the system, it must mist well, it must not produce excessive stray mist

and it must have a pour point high enough to prevent cold weather problems. Experience, in the absence of scientific testing, has shown that an oil with a pour point 20°F above the lowest anticipated temperature will perform well in cold weather. In Southern climates, high-quality, R & O turbine oil will normally do well. In Northern climates, a synthetic might be needed.

Additives are sometimes used in "mist oils" to increase droplet size and minimize stray mist. But, these same additives at higher concentrations, say in engine oils, make the oil almost "unmistable." Gear oils can also be misted, but care must be taken to assure the oil is not too viscous. The oil temperature/oxidation characteristics must be considered. While synthetics may seem like the cure-all, their cost and their environmental friendliness must be taken into account. For instance, in a single line system with a lot of equipment and typically rich oil/air mixture oil costs could become excessive. While oil cost compared to overall operating costs are insignificant, anyone who has been in the petrochemical industry for any time knows that such costs come under very close scrutiny. What oil should be used? Each case requires individual consideration.

Routine Surveillance/Maintenance

Routine surveillance and maintenance are mandatory if an oil mist system is to operate successfully for many years. Besides the routine checks for mist quality, consoles should be checked for proper temperatures and level. Checks should be made at the pumps, motors or other equipment to determine if collection containers need draining, the system is intact, etc.

Routine maintenance should be performed at the console on at least six month intervals. This would include such items as replacing air and oil filters, cleaning the console reservoir/generator head, running the backup generator head, and checking and resetting the alarms and controls where required. Whether this is done as a contract service or by inhouse crafts does not matter. Getting it performed *routinely* does matter.

Environmental/Safety

The two areas where oil mist receives the greatest degree of concern are safety and environmental. Safety issues usually arise about flammability, but a little thought about an oil mist system should allay those fears. As noted previously, a good operating point for oil mist generators is at an oil / air ratio of 0.5 cu in/cfm/hr. Assuming an oil weighs 7.4 #/gallon, then:

$$\frac{0.5 \text{ cu. in.}}{\text{hour}} \times \frac{1 \text{ gallon}}{231 \text{ cu. in.}} \times \frac{7.4 \#}{\text{gallon}} = \frac{0.0160 \# \text{ oil}}{\text{hour}}$$

And for the air:

$$\frac{1 \text{ cu. ft.}}{\text{min}} \times \frac{0.075 \#}{\text{cu. ft.}} \times \frac{60 \text{ min}}{\text{hour}} = \frac{4.5 \# \text{ air / hr}}{\text{hour}}$$

$$\text{so, the air / oil ratio is: } \frac{4.5 \# \text{ air}}{0.0160 \# \text{ oil / hr}} = \frac{281 \# \text{ air}}{\# \text{ oil}}$$

According to the Marks Handbook, the lean limit of combustibility for oil mists is 24:1. Hence, oil mist produced in a mist system is far below the lean limit and will not burn. An additional safety concern is liquid spills and leakage. These issues have been addressed herein. If a system is properly designed and installed and proper attention is paid to correct operation, an oil mist system should not cause any housekeeping or environmental problems. When a system is not properly cared for, housekeeping problems can be significant. Is this the fault of the oil mist system?

Current environmental restrictions that apply to airborne oil mists are the OSHA values of 5.0 mg/m^3 . A number of evaluations have been conducted by corporate environmental departments and have shown concentrations of mists well below the 5.0 mg level. Maximum concentration that this author has observed was approximately 2.0 mg/m^3 and this was when measurements were made at six to twelve inches away from a disconnected 0.18 cfm reclassifier blowing directly into the atmosphere. Other studies have measured concentrations around the pump shaft and at purge mist vents. Values were well below 0.5 mg/m^3 . Hence, given today's limits, oil mist is easily in compliance with the standards.

The more major environmental concern is handling liquid oil that collects. It certainly must not be released to the storm sewer and the amount released to an oily water sewer must be minimized. These issues we addressed earlier in this tutorial when vent and drain systems were discussed. Concerns at each operating plant are different, but there are enough methods available to solve any questions raised. The cost-effectiveness of each solution at each plant must be evaluated and the best one chosen for the application.

THE FUTURE

It is impossible to predict future environmental requirements for oil mists. But, if they become more stringent as anticipated, the closed loop system described throughout this discussion is already available and can be applied. Obviously, initial costs will be increased but they can be offset by the reduced maintenance costs brought about by an oil mist system.

Researchers at Texas A&M University continue to do basic research into oil mist lubrication. Current studies are aimed at determining the impact of oil mist in long term bearing endurance tests. Also included are investigations of aerosol characteristics in the header system and at the reclassifiers. Results from these studies should provide excellent information to significantly improve oil mist system operation.

Empirical work continues in the field to develop improved methods for sealing bearing housings and minimizing stray mist losses through shaft seals and to provide lower cost, closed loop systems.

CONCLUSION

Oil mist lubrication is an effective method for reducing lubrication related bearing failures in rotating machinery in the petrochemical industry. Numerous studies have shown these advantages. A wide variety of equipment including pumps, motors, gear boxes, and steam turbines have been successfully converted to oil mist. Concerns about safety and environmental issues have been addressed and properly designed, installed and operated oil mist system satisfies all requirements. An oil mist system is very reliable and because it is, it can easily be forgotten. Routine surveillance and maintenance programs are mandatory if an oil mist system is to continue to perform reliably for extended periods. A well designed, installed and maintained oil mist system can make a significant contribution to improved reliability and operability of refineries and chemical plants.

REFERENCES

1. Anonymous, "Oil Mist Arrests Bearing Failure in Aruba," *Oil and Gas Journal* (September 16, 1974).
2. Bloch, H. P., "Large Scale Application of Pure Oil Mist Lubrication in the Petrochemical Plant," ASME Paper 80-C12/LUB-25 (1980).
3. Bloch, H. P., "Optimized Lubrication of Anti-friction Bearings for Centrifugal Pumps," ASLE Paper 79-AM-ID-2 (April 1978).
4. Bloch, H. P., "Lubrication Strategies for Electric Motor Bearings in the Petrochemical and Refining Industries," NPRA Paper MC-84-10, San Antonio, Texas (February 1984).
5. Clapp, A. M., "Plant Lubrication," *Proceedings of the Seventh Turbomachinery Symposium*, The turbomachinery Laboratory, Texas A&M University, College Station, Texas, (1978).
6. Mianney, C. R., "Improve Bearing Life with Oil Mist Lubrication," *Hydrocarbon Processing*, 54 (5), pp. 113-115 (1974).
7. Towne, C. A., "Practical Experience with Oil Mist Lubrication," ASLE Paper 82-AM-4C1, Cincinnati, Ohio (1982).
8. Bloch, H. P., *Oil Mist Lubrication*, Houston, Texas: Gulf publishing Company (1987).
9. Towne, C. A. and Sheppard, D. J., "Oil Mist Lubrication for Electric Motors—Where It Stands Today," *IEEE Transactions on Industry Applications*, IA-22 (6) (November/December 1986).
10. Shamin, A., "Design, Fabrication and Testing of a Bearing Test Rig and Preliminary Studies on Oil Mist Lubrication," M.S. Thesis, Department of Mechanical Engineering, Texas A&M University (1990).

ACKNOWLEDGEMENTS

The author wishes to thank T. K. Ward and F. Paben of Lubrication Systems Company for their assistance in providing materials and guidance for this paper. Thanks also go to C.F. Kettleborough of the Turbomachinery Laboratory at Texas A&M University for his permission to mention unpublished results from the research work being conducted his guidance and to Abdus Shamim who has so ably conducted the program at Texas A&M. And thanks to Corbin Spitzer of Bill Spitzer and Associates for his advice and support of this paper.